

ขนาดทั่วไปของข้อต่อท่อพีวีซีแข็ง "ท่อน้ำไทย" สำหรับใช้กับท่อรับความดันต่ำและท่อเกษตร

COMMON SIZES OF TS FITTINGS FOR LOW PRESSURE AND AGRICULTURAL PIPE

ข้อต่อท่อพีวีซีแข็งประเภทที่ทำด้วยวิธีอัดแบบชนิดฉีด TS FITTING BY INJECTION MOULDING

Unit:mm

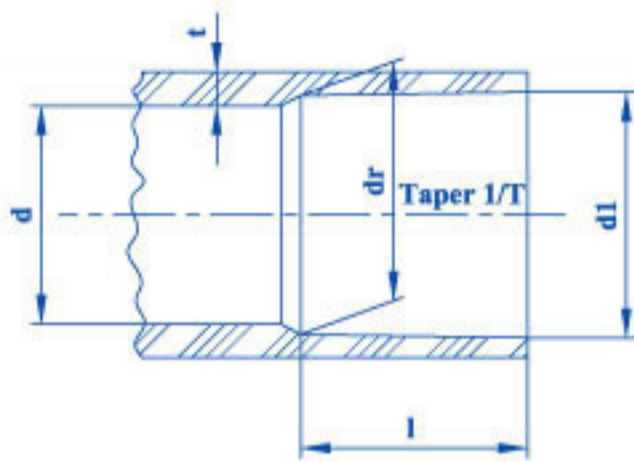

ชื่อขนาด NOMINAL SIZE	d1	dr	l	1/T	d	t
10 (1/4")	14.30+0.20	13.60	21	1/30	12	2.25
15 (3/8")	18.40+0.20	17.54	26	1/30	13	2.25
18 (1/2")	22.40+0.20	21.40	30	1/34	16	2.25
20 (3/4")	26.45+0.20	25.27	35	1/34	20	2.25
25 (1")	34.55+0.25	33.00	41	1/34	28	2.25
35 (1 1/4")	42.60+0.25	40.73	46	1/34	35	2.25
40 (1 1/2")	48.70+0.30	46.53	55	1/37	40	2.63
55 (2")	60.80+0.30	58.12	63	1/37	51	2.31
65 (2 1/2")	76.60+0.30	73.62	63	1/48	67	4.06
80 (3")	89.60+0.30	86.18	64	1/49	77	4.75
100 (4")	114.70+0.30	110.44	84	1/56	100	6.06

ข้อต่อท่อพีวีซีแข็งประเภทที่ทำด้วยวิธีขึ้นรูปด้วยความร้อน TS FITTINGS BY HEAT FABRICATION

Unit:mm

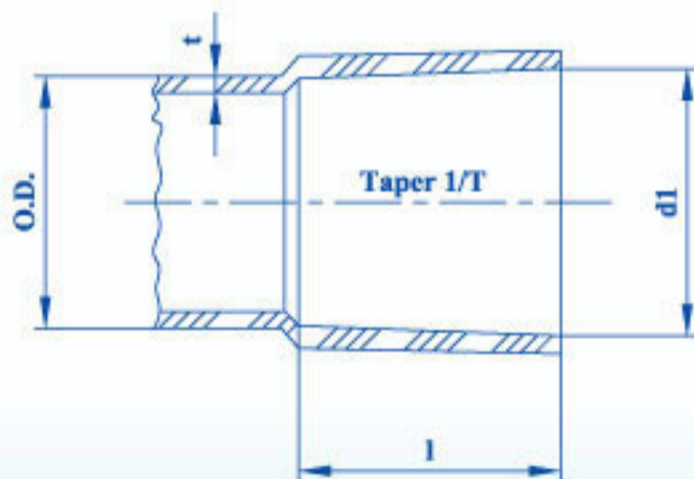

ชื่อขนาด NOMINAL SIZE	d1	l	1/T	O.D.	t
10 (1/4")	14.2+0.2	14+3	1/30	14	1.0
15 (3/8")	18.3+0.2	18+3	1/30	18	1.0
18 (1/2")	22.3+0.2	20+3	1/30	22	1.0
20 (3/4")	26.4+0.2	24+3	1/30	26	1.1
25 (1")	34.4+0.2	26+3	1/32	34	1.1
35 (1 1/4")	42.4+0.2	30+3	1/32	42	1.2
40 (1 1/2")	48.5+0.3	35+3	1/34	48	1.2
55 (2")	60.5+0.3	40+3	1/35	60	1.4
65 (2 1/2")	76.5+0.3	50+5	1/45	76	1.7
80 (3")	89.5+0.3	55+5	1/46	89	2.2
100 (4")	114.6+0.3	70+5	1/53	114	2.5
125 (5")	140.7+0.4	90+5	1/55	140	3.2

