

ข้อต่อลด

TS REDUCING SOCKET

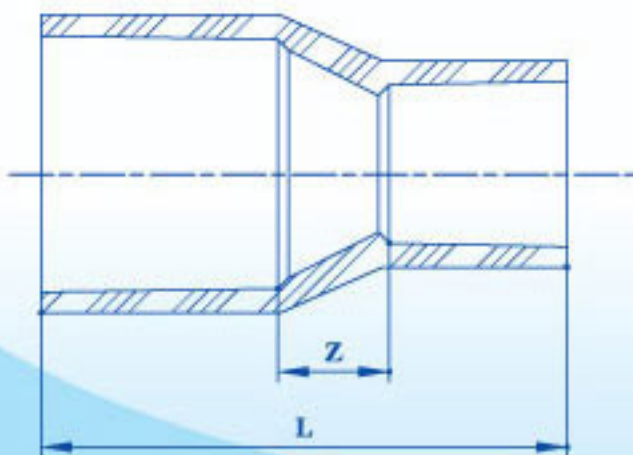

Unit:mm

ชื่อขนาด NOMINAL SIZE	L	Z
20x18 (3/4"x1/2")	71	6
25x18 (1"x1/2")	84	13
25x20 (1"x3/4")	84	8
35x20 (1 1/4"x3/4")	93	12
35x25 (1 1/4"x1")	93	6
40x18 (1 1/2"x1/2")	114	29
40x20 (1 1/2"x3/4")	114	24
40x25 (1 1/2"x1")	114	18
40x35 (1 1/2"x1 1/4")	114	13
55x18 (2"x1/2")	136	43
55x20 (2"x3/4")	136	38
55x25 (2"x1")	136	32
55x35 (2"x1 1/4")	136	27
55x40 (2"x1 1/2")	136	18
65x20 (2 1/2"x3/4")	149	51
65x25 (2 1/2"x1")	149	45
• 65x35 (2 1/2"x1 1/4")	149	40

Unit:mm

ชื่อขนาด NOMINAL SIZE	L	Z
65x40 (2 1/2"x1 1/2")	149	31
65x55 (2 1/2"x2")	149	23
80x35 (3"x1 1/4")	165	55
80x40 (3"x1 1/2")	165	46
80x55 (3"x2")	165	38
80x65 (3"x2 1/2")	165	38
100x40 (4"x1 1/2")	190	51
100x55 (4"x2")	190	43
100x65 (4"x2 1/2")	190	43
100x80 (4"x3")	190	42
• 125x55 (5"x2")	230	63
• 125x65 (5"x2 1/2")	230	63
• 125x80 (5"x3")	230	62
• 125x100 (5"x4")	230	42
• 150x80 (6"x3")	295	99
• 150x100 (6"x4")	295	79
• 150x125 (6"x5")	295	59

- หมายเหตุ :
1. เกณฑ์ความคลาดเคลื่อน (tolerance) ของ L = ± 4 มม.
 2. • บริษัทฯ ยังไม่มีการผลิตออกจำหน่าย
 3. บริษัทฯ มีผลิตสีขาว ขนาด 20x18 มม. - 100x80 มม.

